

DF005S THRU DF10S

MINIATURE GLASS PASSIVATED SINGLE-PHASE SURFACE MOUNT BRIDGE RECTIFIER

Reverse Voltage - 50 to 1000 Volts Forward Current - 1.0 Ampere

Case Style DFS

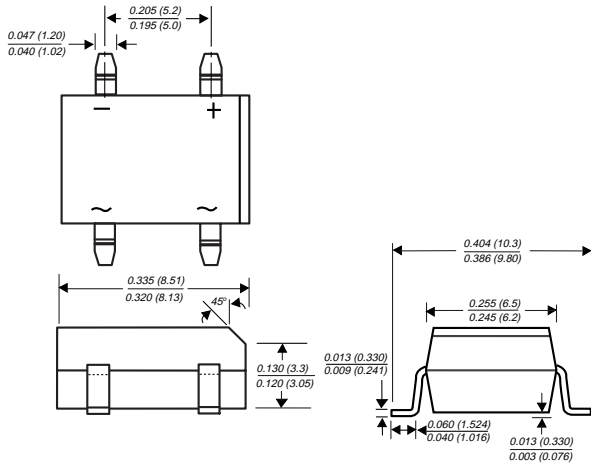

Dimensions in inches and (millimeters)

FEATURES

- ◆ Plastic package has Underwriters Laboratory Flammability Classification 94V-0
- ◆ This series is UL recognized under Component Index, file number E54214
- ◆ Glass passivated chip junctions
- ◆ High surge overload rating-50 amperes peak
- ◆ Ideal for printed circuit boards
- ◆ High temperature soldering guaranteed:
260°C/10 seconds at 5 lbs. (2.3kg) tension



MECHANICAL DATA

Case: Molded plastic body over passivated junctions

Terminals: Plated leads solderable per MIL-STD-750, Method 2026

Polarity: Polarity symbols marked on body

Mounting Position: Any

Weight: 0.04 ounce, 1.0 gram

MAXIMUM RATINGS AND ELECTRICAL CHARACTERISTICS

Ratings at 25°C ambient temperature unless otherwise specified.

	SYMBOLS	DF 005S	DF 01S	DF 02S	DF 04S	DF 06S	DF 08S	DF 10S	UNITS
Maximum repetitive peak reverse voltage	V _{RRM}	50	100	200	400	600	800	1000	Volts
Maximum RMS voltage	V _{RMS}	35	70	140	280	420	560	700	Volts
Maximum DC blocking voltage	V _{DC}	50	100	200	400	600	800	1000	Volts
Maximum average forward output rectified current at T _A =40°C (NOTE 2)	I _(AV)	1.0							Amp
Peak forward surge current single half sine-wave superimposed on rated load (JEDEC Method) T _J =150°C	I _{FSM}	50.0							Amps
Rating for fusing (t < 8.3ms)	I ² t	10.0							A ² sec
Maximum instantaneous forward voltage drop per leg at 1.0A	V _F	1.1							Volts
Maximum DC reverse current at rated DC blocking voltage per leg	I _R	5.0 500							μA
Typical junction capacitance per leg (NOTE 1)	C _J	25.0							pF
Typical thermal resistance per leg (NOTE 2)	R _{θJA} R _{θJL}	40.0 15.0							°C/W
Operating junction and storage temperature range	T _J , T _{STG}	-55 to +150							°C

NOTES:

- (1) Measured at 1.0 MHz and applied reverse voltage of 4.0 Volts
- (2) Units mounted on P.C.B. with 0.51 x 0.51" (13 x 13mm) copper pads

RATINGS AND CHARACTERISTICS CURVES DF005S THRU DF10S

FIG. 1 - DERATING CURVE OUTPUT RECTIFIED CURRENT

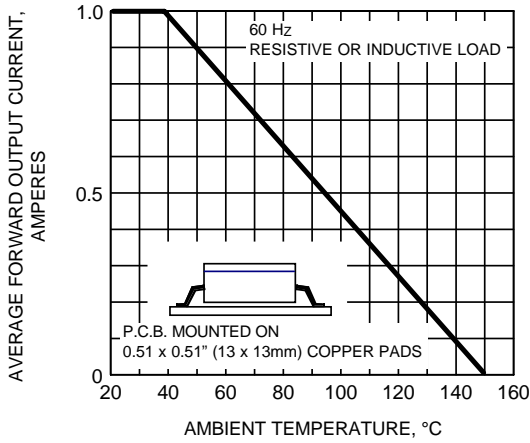

FIG. 2 - MAXIMUM NON-REPETITIVE PEAK FORWARD SURGE CURRENT PER LEG

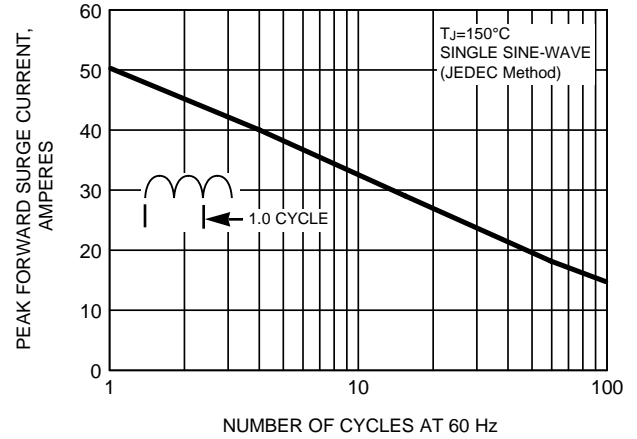

FIG. 3 - TYPICAL FORWARD CHARACTERISTICS PER LEG

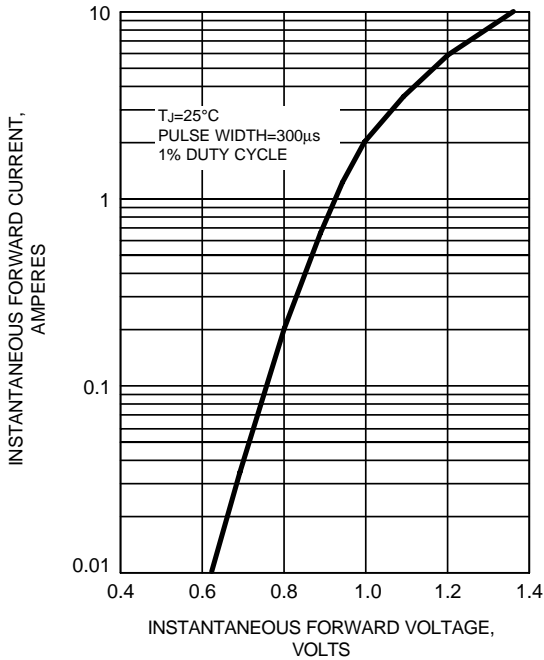

FIG. 4 - TYPICAL REVERSE LEAKAGE CHARACTERISTICS PER LEG

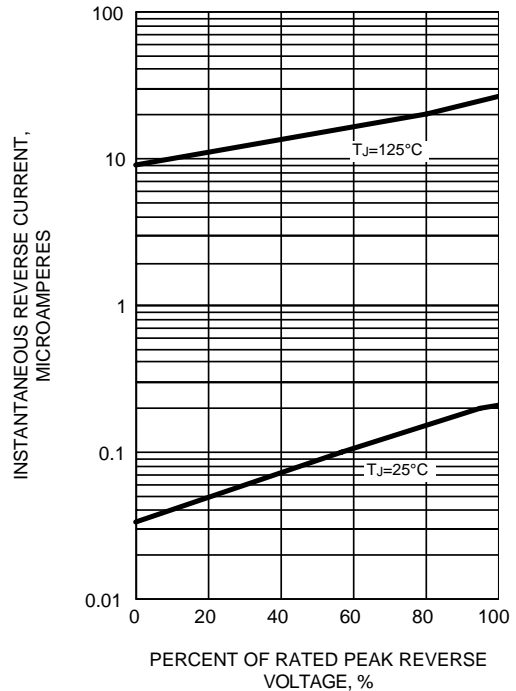

FIG. 5 - TYPICAL JUNCTION CAPACITANCE

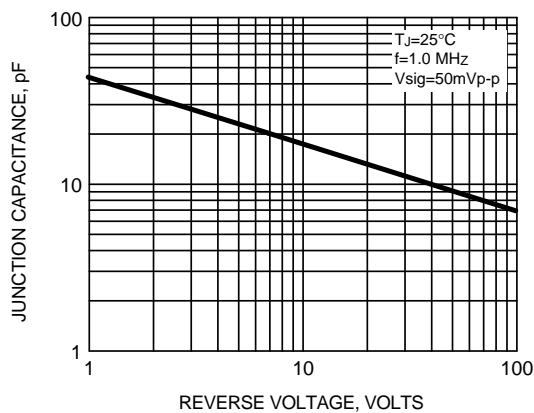

FIG. 6 - TYPICAL TRANSIENT THERMAL IMPEDANCE

